



# LM2000/LM2000S Lube Level Maintainer Installation Instructions

Please read the following information before installing. A visual inspection of this product for damage during shipping is recommended before mounting. **CRANKCASE MUST BE DRAINED BEFORE INSTALLATION.**

## GENERAL INFORMATION

# WARNING

**BEFORE BEGINNING INSTALLATION OF THIS MURPHY PRODUCT**

- Disconnect all electrical power to the machine.
- Make sure the machine cannot operate during installation.
- Follow all safety warnings of the machine manufacturer.
- Read and follow all installation instructions.



### Description

The Murphy LM2000 model maintains the crankcase oil level of an engine, pump or compressor. Adjusted to the correct *running-oil-level*, the LM2000 will replenish oil as it is used. An integral, low-level switch will alarm and/or shut-down the equipment if supply oil is lost and the equipment continues to use oil.

### Specifications

- Crankcase Balance Vent Connection:** 1/2 NPTF (top).  
**Inlet Connection:** 1/2 NPTF with removable screen (side).  
**Outlet Connection:** LM2000 3/4 NPTF (bottom).  
 LM2000S 2 x 3/8 NPTF (side)  
 1 x 3/4 NPTF (bottom)

- Thumb-Valve™ Material:** Viton.  
**Snap-switch:** SPDT rating 10 A, 125 VAC; 0.5 A, 125 VDC; 10 A, 30 VDC.  
**Wire leads:** 18 AWG x 24 in.(609 mm) length.  
**Conduit Connection:** 1/2 inch conduit (female, top).  
**Case:** Die cast aluminum  
**Lens:** Clear “Frog Eye” non-staining, high impact, high temperature nylon; UV and heat stabilized.  
**Dial:** High visibility white background with green and white “index” lines for normal level indication.  
**Maximum Inlet Pressure:** 9.50 psi/25 ft. oil (head pressure).  
**Maximum Case Pressure:** 15 psi (103 kPa).  
**Maximum Differential:** 2 in. (51 mm) between running and stopped.  
**Maximum Ambient Temperature:** 250°F (121°C).  
**Float:** Brass  
**Flow Rates:** SAE 40 motor oil @ 32°F (0°C) with 2 ft. head pressure: 0.5 GPH (1.9 LPH).

*NOTE: Friction losses due to piping not considered.*

### Optional Vent Fittings Kit: 15000954

The 15000943 kit is sold separately. It includes the following items:

Quantity	Description
1	Tubing vent (15050202).
1	1/4 x 1/4 NPT Connector (85030447).

### Optional Hose Kit: 15000355

Quantity	Description
1	1/2 in. (13 mm) I.D. x 3 ft. (914 mm) long hose (89020202)
1	1 in. (25 mm) I.D. x 3 ft. (914 mm) long hose (89020203)
2	1/2 in. (13 mm) worm gear clamp (00003502)
2	1 in. (25 mm) worm gear clamp (00003503)
2	1/2 NPT x 1/2 in. (13 mm) barbed fitting (89080801)
2	3/4 NPT x 1 in. (25 mm) barbed fitting (89081001)

### Thumb-Valve™ Operation

As the equipment uses oil, the float falls, providing immediate level compensation. At FULL position, the float holds the valve closed. If the clean oil supply is depleted and oil level continues to fall, the low level switch will operate an alarm or equipment shutdown.

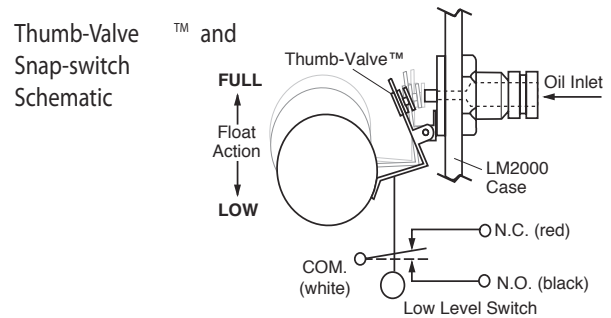

### Service Parts (Specify part number)

Description	Part Number
Vent Fittings Kit	15000954
Hose Kit	15000355
1/2NPT x 1/2 in. Hose Barbed Fitting	89080801
3/4NPT x 1/2 in. Hose Barbed Fitting	89081001
3/8NPTF x 1/2 in. Hose Barbed Fitting	89080601
Pipe Bracket Kit	15000238
Universal Flange Kit	15010224

## DIMENSIONS

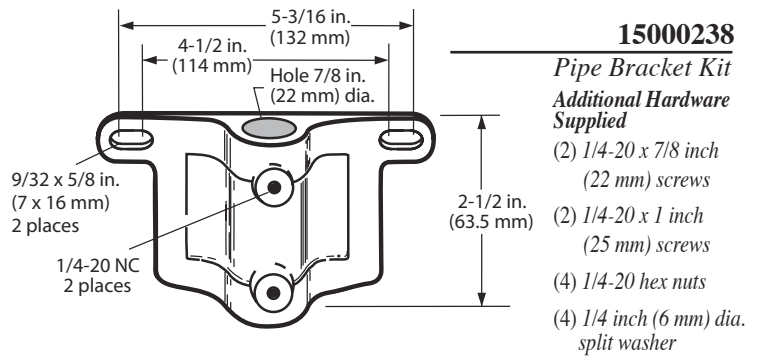
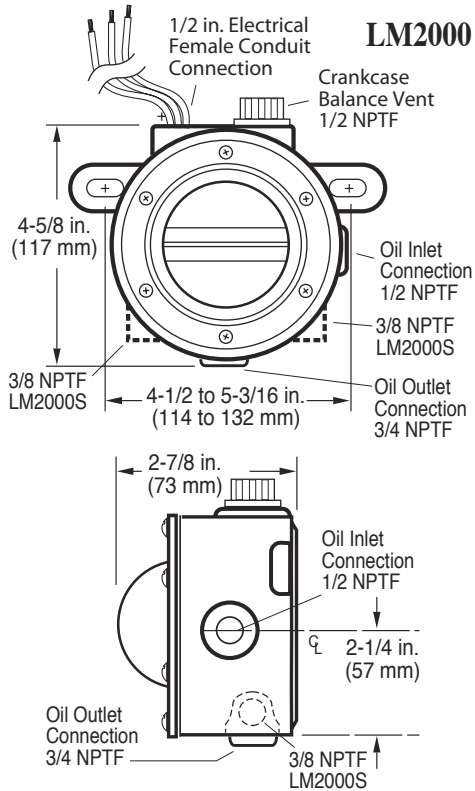

### 15010224

#### Universal Flange Kit

##### Additional Hardware Supplied

- (2) 1/4-20 x 1/4 inch (32 mm) bolts
- (4) 1/4 inch dia. flat washer
- (2) 1/4-20 hex nuts
- (2) 5/16-18 x 1/4 inch (32 mm) bolts
- (4) 5/16 dia. flat washer
- (2) 5/16-18 hex nuts

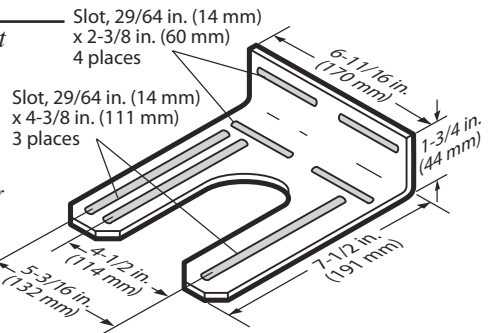

## TYPICAL INSTALLATION

### Mounting the LM2000

**NOTE:** Mount the LM2000 as close as possible to the crankcase.



**CAUTION:** Excessive vibration can cause over-fill. Be sure mounting brackets are supported.

The following instructions are based on the usage of the pipe and universal mounting brackets shown above.

#### Pipe Bracket Mounting (15000238)

1. Mount a nominal 1/2 inch (13 mm) diameter pipe to the base of the engine.
2. Install the pipe bracket to the LM2000 using two 1/4-20 UNC x 1 inch bolts, nuts and lock washers supplied. See Figure 1A.
3. Slip the LM2000 onto the pipe and install the two adjustment bolts. Each bolt consists of a 1/4-20 UNC x 1 inch bolt, nuts and lock washers. See Figure 1B. **DO NOT** tighten the adjustment screws too tightly because you will have to adjust the LM2000 later in the installation process.

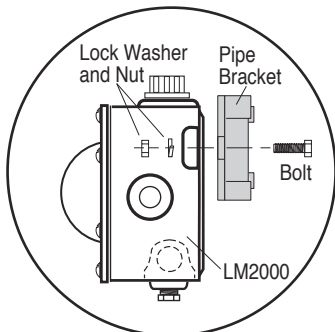

Figure 1A

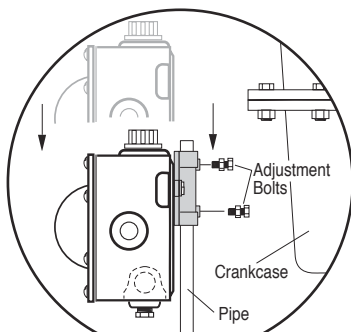

Figure 1B

### Mounting with Universal Bracket (15000370)

The universal bracket has two mounting methods: base mounting or pan mounting.

#### Base Mounting

1. Install the universal bracket to the base as shown in Figure 2A using two flat washers and two 5/16 inch dia. bolts or others as necessary.

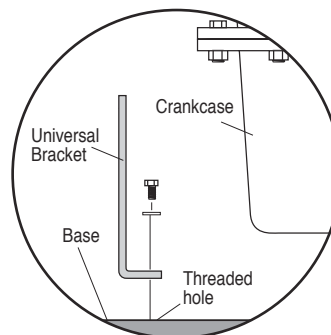

Figure 2A

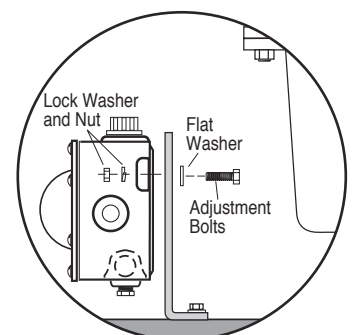

Figure 2B

2. Mount the LM2000 to the universal bracket using two 1/4-20 UNC x 1-1/4 inch (32 mm) bolts, nuts and lock washers supplied (Figure 2B). **DO NOT** tighten the adjustment screws too tightly. You will have to adjust the LM2000 later in the installation process.

## TYPICAL INSTALLATION

### Crankcase (Oil Pan) Mounting

1. Install the universal bracket to the crankcase using the existing crankcase bolts (Figure 3A). Crankcase bolt diameter must be no larger than 7/16 inch (11 mm).

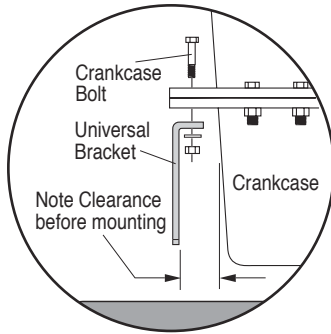

Figure 3A

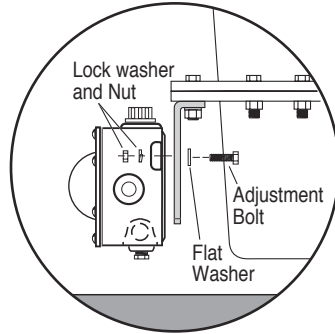

Figure 3B

**NOTE:** Check clearance between crankcase and mounting bracket before installing the mounting bracket. If space between the crankcase and mounting bracket does not allow installation and access to the adjustment bolts advance to Step 3.

2. Mount the LM2000 to the universal bracket using two 1/4-20 UNC x 1-1/4 inch bolts, nuts and lock washers supplied. **DO NOT** tighten the adjustment bolts too tight. You will have to adjust the LM2000 later in the installation process.
3. If space between the crankcase and mounting bracket is narrow, install the universal mounting bracket to the LM2000 before installing to the crankcase oil pan.

### Connecting Fittings and Hoses

The following instructions are based on the Murphy optional hose kit described on page 1. If you did not order the optional hose kit, use the list designation as a guide to the required materials.

1. Install the LM2000 fittings in their proper locations. **NOTE:** Apply a sealant such as Teflon<sup>®</sup>, to all threaded connections.
2. Attach the 1 inch (25 mm) diameter, flexible monitoring hose to the crankcase and the monitoring port on the LM2000. See Figure 4. **CAUTION:** The hose must slope slightly downward from the LM2000 and **MUST NOT** have any droops or low spots.

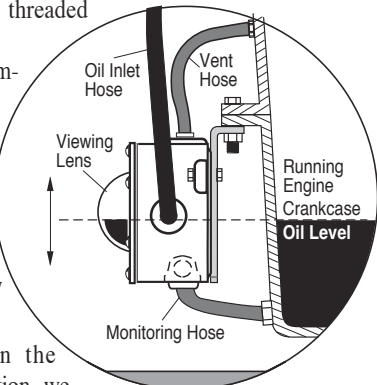

Figure 4

**NOTE:** If the drain plug on the crankcase is used for the connection, we recommend installation of a tee to allow draining of the crankcase for service.

3. Install the 1/2 inch (13 mm) I.D. x 3 ft. (914 mm) hose to the vent connection on the LM2000 and to the vent connection on the crankcase. See Figure 4. **The vent connection on the crankcase must be well above the regulated oil level.** All hoses must be clear of obstructions, valleys, or dips that could create liquid traps, or gas/air pockets. The vent and crankcase connections should be as straight as possible.

**BEFORE CONTINUING, VERIFY THAT ALL HOSE CLAMPS ARE TIGHT.**

4. Fill the crankcase to the proper oil level. With the engine running and warm, loosen the mounting bracket adjustment bolts and adjust the LM2000 so that the oil level in the sight gauge is aligned with the white “index line” on the dial (Figure 4). Tighten the adjustment bolts securely.

### Connecting the LM2000 to an Oil Supply Tank

1. Remove the plug from the oil inlet connection. Be sure the removable screen, inside the connection, is clear of debris. Install the oil inlet connection.
2. Connect a 1/2 inch I.D. (13 mm) or larger hose to the oil inlet fitting on the LM2000 and to the shutoff valve on the oil supply tank. See Figure 5. Recommended minimum height above the LM2000 is 2 ft. (0.6m); maximum 25 ft. (7.7m). The hose must maintain a downward slope and not have low spots or droops. Maximum head pressure rating is 9.50 psi or 25 ft oil (head pressure).
3. Before filling the supply tank with oil, be sure the tank is clean and dry and the shutoff valve is closed. Also, be sure all hoses and clamps are tight. Fill the tank with **CLEAN** oil.

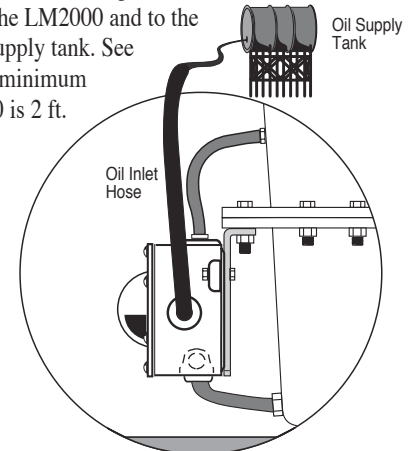

Figure 5



**WARNING:** Overfill condition can be caused by excessive inlet pressure and/or improper “vent to crankcase” installation.

4. After oil supply tank is full, open the shutoff valve.

Next, make the proper electrical connections for the application. (See Snap-switch ratings and schematic on page 1.)

### Switch Test

To test the shutdown or alarm functions perform the following:

**NOTE:** Installations with closed vent systems can only be tested with the engine off.

1. Unscrew the vent fittings.
2. Using a long narrow shank screw driver, gently insert until contact is felt with float arm. Gently push the float arm down.
3. Verify proper switch operation

## LM2000 Typical Installation Shown with FSV Series Valves



**WARNING:** Perform this installation using appropriate protection. Trapped air and hot oil may cause burns.

### LM2000 Typical Installation

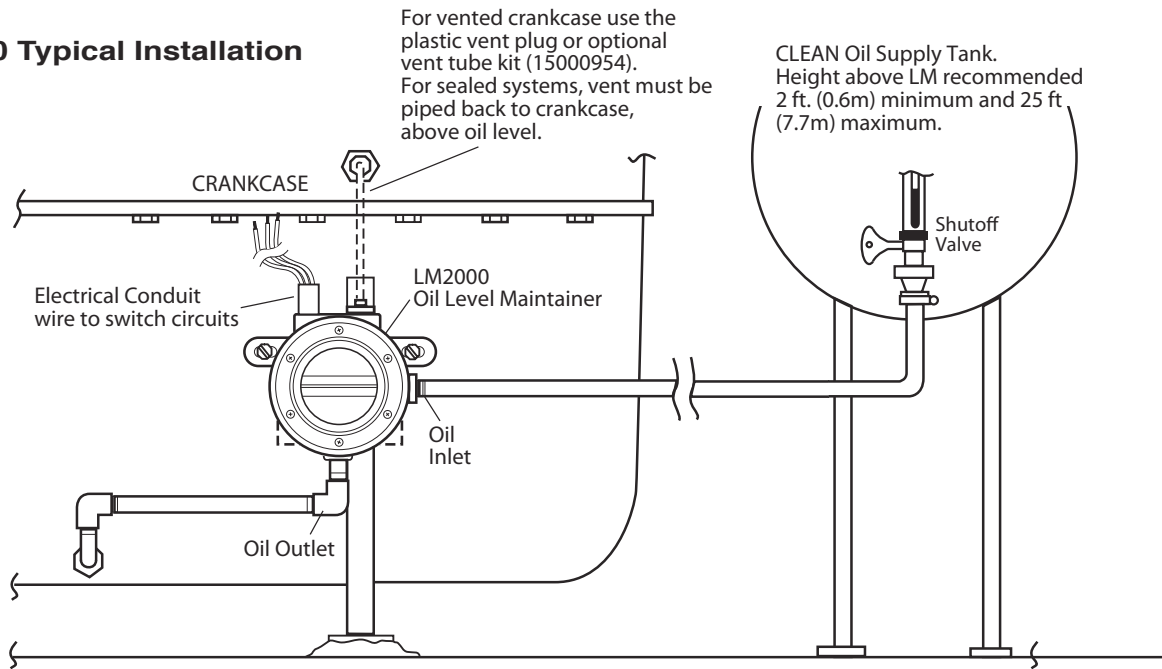

## OPERATING RANGE OF THE SNAP-SWITCH

Figure 6 shows the LM2000 dial and the operating range of the switch. If level is within the designated zones the switch will activate.

The switch activates approximately 1/4 in. (6 mm) from the bottom of the low zone. The dial in Figure 6 shows that if level continues to drop into the low-low zone, a shutdown will occur.

**NOTE:** Color zones on dial face show approximate normal operating zones. Actual conditions may vary depending upon operating characteristics of the engine. Placement of the LM2000 according to the above instructions will compensate for these conditions.

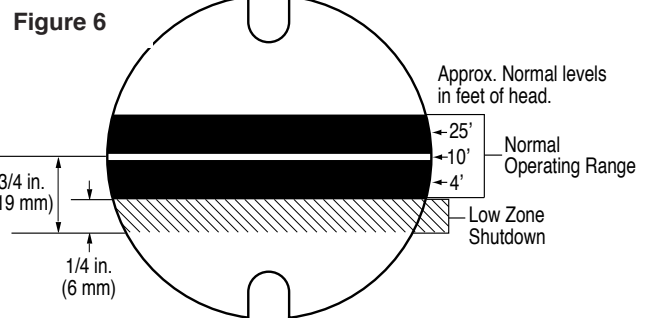

### Warranty

A two-year warranty on materials and workmanship is given with this FWMurphy product. A copy of the warranty may be viewed or printed by going to [www.fwmurphy.com/warranty.asp](http://www.fwmurphy.com/warranty.asp).

Call MurCal To Place Your Order

