

Level Maintainer



LM300 Series

- Maintains proper lube level
- Shutdown on low level, or high and low level
- Low level alarm before shutdown
- Manual float switch test
- High visibility "Frog Eye" lens
- Optional pipe or universal mounting brackets
- Optional inlet orifices for low to high pressure applications
- Explosion-proof models available

Description

The LM300 Series Level Maintainer automatically adds oil to the crankcase as needed to keep the lube level normal. Most models have built-in switches that will alarm and/or shutdown the equipment if the makeup supply is depleted and engine oil level falls or if overfill conditions exist. LM300 series explosion-proof models are CSA certified^{††} for Class I, Division 1 Hazardous areas.

Applications

- Engines
- Pumps
- Compressors
- Coolers

Specifications

Case/Cover: Die cast aluminum.

Switch Housing: Aluminum.

Approval Rating: LM301 thru LM305 : CSA certified^{††} for non hazardous locations.

Enclosure Type 4 certified.

LM301-EX thru LM305-EX: CSA certified^{††} for Class I, Groups C and D; Class II, Groups F and G hazardous locations. *Enclosure Type 4 certified.*

Float: Rigid polyurethane foam. Polyurethane coated.

Max. Ambient Temperature: 250°F (121°C)

Oil Inlet Connection: Top entry 1/2-14 NPT with built-in filter screen (removable for cleaning).

Inlet Orifices: 1/4 in. (6 mm) standard.
1/8 in. (3 mm) available.

Wire (switch models): 18 AWG x 13 in.
(1.0 mm² x 330 mm).

Max. Inlet Pressure (MIP):
30 psi (207 kPa) [2.07 bar].
with 1/8 in. (3 mm) orifice.
15 ft oil (4.6 m oil)
with 1/4 in. (6 mm) orifice.

Max. Differential: 2 in. (51 mm) between running and stationary oil level.

Max. Case Pressure (MCP):
15 psi (103 kPa) [1.03 bar].

Orifice Seal[†]: Buna-N Thumb-Valve™

Switch Contact: Silver, SPDT snap acting, rated at 10 A @ 125, 250 VAC; 10 A @ 30 VDC.
(1 only for low level; 2 only for high and low; or 2 only for low level with alarm before shutdown)

Flow Rate Test: Using SAE 30 @ 32°F (0°C).

Orifice Diameter	Pressure	Flow Rates
1/4 in.* (6 mm)	4 ft. oil – 15 ft. oil (1.2 m oil – 4.6 m oil)	4.7 GPH - 31.0 GPH (17.8 LPH - 117.3 LPH)
1/8 in. (3 mm)	10 psig – 30 psig (68.9 kPa – 207 kPa) [.69 – 2.07 bar]	16.9 GPH - 32.1 GPH (63.7 LPH - 121.5 LPH)

*Standard

NOTE: Friction losses due to piping **NOT** considered.

Outlet Connection: 3/4-14 NPT left side, right side, and bottom.

Crankcase Balance Vent Fitting: 1/2-14 NPT.

Mounting: Accepts Murphy pipe mounting bracket or universal mounting bracket.

Lens: Clear "Frog Eye" non-staining, high impact, high temperature nylon; UV and heat stabilized.

Dial: High visibility white background with green and white "index" lines for normal level indication.

Test Knob: Rotate to test switch operation. Turn clockwise for low level test and turn counterclockwise for high level test.

Optional Hose Kit: 15000355

Quantity	Description
1	1/2 in. (13 mm) I.D. x 3 ft. (914 mm) long hose
1	1 in. (25 mm) I.D. x 3 ft. (914 mm) long hose
2	1/2 in. (13 mm) worm gear clamp
2	1 in. (25 mm) worm gear clamp
2	1/2 NPT x 1/2 in. (13 mm) barbed fitting
2	3/4 NPT x 1 in. (25 mm) barbed fitting

Base Models*

LM300: Level Maintainer only (no switches).

LM301: Low switch contacts for low level shutdown or alarm. Four wires, SPDT.

LM302: Two switches for low and high level shutdown or alarm. Four wires, DPST, wired N.O. in normal operating ranges.

LM303: Two switches for low and high level shutdown or alarm. Four wires, DPST, wired N.C. in normal operating ranges.

LM304: Two switches. Alarm before shutdown on low level and shutdown on low-low level. Four wires, DPST, wired N.O. in normal operating ranges.

LM305: Two switches. Alarm before shutdown on low level and shutdown on low-low level. Four wires, DPST, wired N.C. in normal operating ranges.

*Specify "EX" for explosion-proof enclosure. All models except LM300 are available in an explosion-proof enclosure.

**Products covered by this bulletin comply with EMC Council directive 89/336/EEC regarding electromagnetic compatibility except as noted.

††CSA certified with switch contacts rated at 10 A at 250 V AC (standard).

Call MurCal To Place Your Order



Dimensions

The dimensions below are for the optional "EX" model enclosure. The standard model enclosure dimensions are the same except the height and width which are: 7 in. (178 mm) H, 7-7/8 in. (200 mm) W.

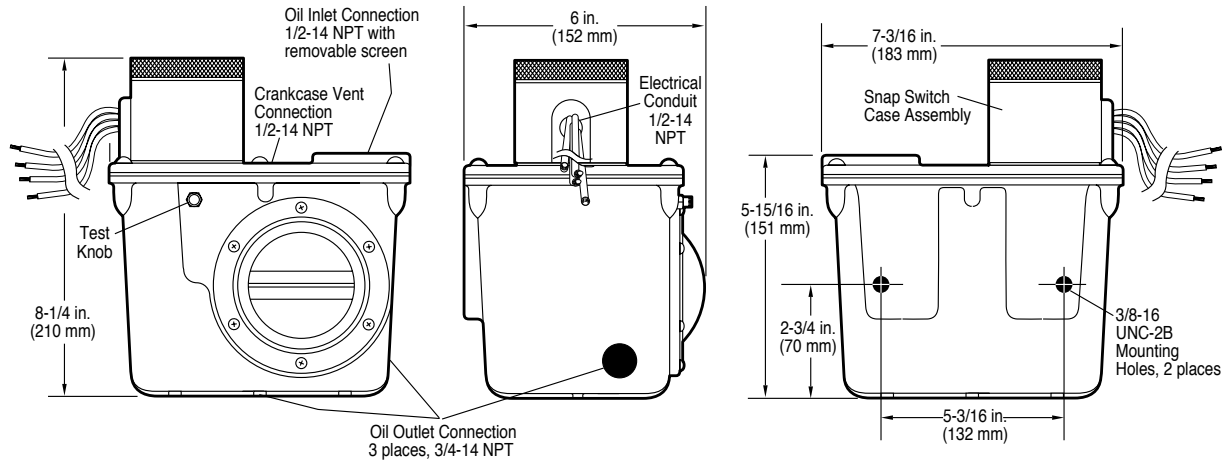

Mounting Brackets with Hardware

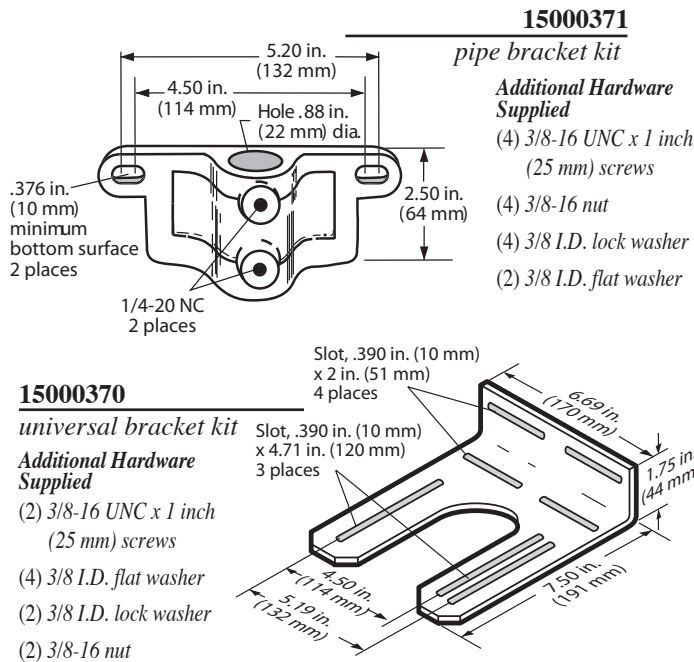

How to Order

Build a complete model number using the following chart. See example. See reverse page for standard and optional specifications.

Example model number

LM301 - LC - EX - A - G

Contacts

Blank = Silver SPDT
10 A @ 125, 250 VAC
10 A @ 30 VDC

Orifices

Blank: 1/4 in. (6 mm)
A: 1/8 in. (3 mm)

Enclosure

Blank: Non-Explosion-proof
EX: Explosion-proof

Variant

LC = Less Case

Base Model: see reverse side for base model descriptions

LM300 (NOT available in EX enclosure)
LM301
LM302
LM303
LM304
LM305

Hose Kit, Mounting Brackets and Lens assembly

Order as separate items:

15000371: pipe bracket kit
15000370: universal bracket kit
15000355: hose kit
15000354: bubble lens assembly

Shipping Information

Shipping Weights:

- LM300 Series non-"EX" models: 6 lbs. 6 ozs. (2.89 kg)
- LM300 Series "EX" models: 6 lbs. 12 ozs. (3.06 kg)

Shipping Dimensions (all LM300 Series models):

- 10-5/8 x 8-7/8 x 6-3/4 in. (270 x 225 x 171 mm)

Warranty

A limited warranty on materials and workmanship is given with this FW Murphy product. A copy of the warranty may be viewed or printed by going to www.fwmurphy.com/support/warranty.htm



Call MurCal To Place Your Order



(661) 272-4700 Fax: (661) 947-7570
www.murcal.com email: sales@murcal.com



USA-ISO 9001:2000 FM 28221
UK-ISO 9001:2000 FM 29422