

Murphy Temperature SWITCHGAGE® and MURPHYGAGE® Thermowell Specifications

T-9003B
Revised 02-04
Catalog Section 10
(00-02-0046)

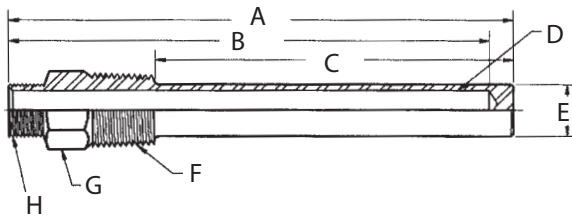
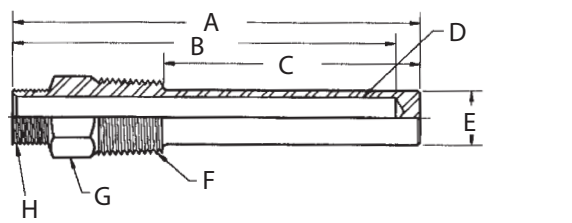
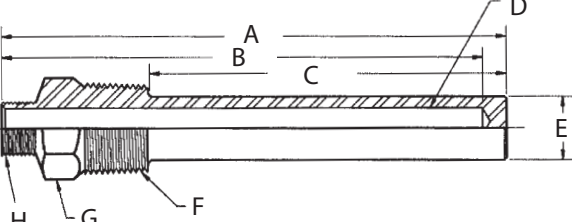
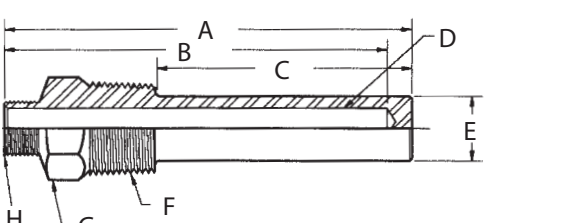
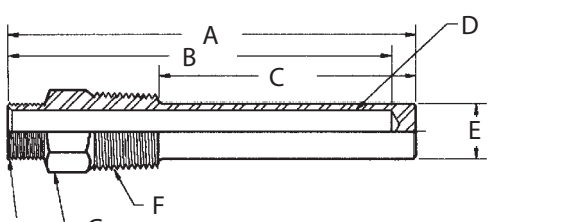

SPL and 45TE Series Thermowells

PART NO.	DIMENSIONS	SPECIFICATIONS
10-00-0582	 <p>A: 6.375 in. (162 mm) B: 6.050 in. (154 mm) C: 4.536 in. (115 mm) D: 0.510 in. (13 mm) E: 0.660 in. (17 mm) F: 1/2-14 NPT G: 0.875 Hex H: 11/16-20 UN-2A</p>	<ul style="list-style-type: none"> • Used with SPLC and 45TE • Rated: 5000 psi @ 300°F (345 bars @ 148°C) • Material: 304 Stainless Steel • Furnished with Compression Nut and Ferrule
10-00-0583	 <p>A: 5.000 in. (127 mm) B: 4.680 in. (119 mm) C: 3.160 in. (80 mm) D: 0.510 in. (13 mm) E: 0.660 in. (17 mm) F: 1/2-14 NPT G: 0.875 Hex H: 11/16-20 UN-2A</p>	<ul style="list-style-type: none"> • Used with SPLC and 45TE • Rated: 5000 psi @ 300°F (345 bars @ 148°C) • Material: 304 Stainless Steel • Furnished with Compression Nut and Ferrule
10-00-0584	 <p>A: 6.375 in. (162 mm) B: 6.050 in. (154 mm) C: 4.524 in. (115 mm) D: 0.510 in. (13 mm) E: 0.810 in. (21 mm) F: 3/4-14 NPT G: 1.125 Hex H: 11/16-20 UN-2A</p>	<ul style="list-style-type: none"> • Used with SPLC and 45TE • Rated: 7000 psi @ 300°F (483 bars @ 148°C) • Material: 304 Stainless Steel • Furnished with Compression Nut and Ferrule
10-00-0585	 <p>A: 5.000 in. (127 mm) B: 4.680 in. (119 mm) C: 3.150 in. (80 mm) D: 0.510 in. (13 mm) E: 0.810 in. (21 mm) F: 3/4-14 NPT G: 1.125 Hex H: 11/16-20 UN-2A</p>	<ul style="list-style-type: none"> • Used with SPLC and 45TE • Rated: 7000 psi @ 300°F (483 bars @ 148°C) • Material: 304 Stainless Steel • Furnished with Compression Nut and Ferrule
10-00-0668	 <p>A: 5.000 in. (127 mm) B: 4.680 in. (119 mm) C: 3.160 in. (80 mm) D: 0.510 in. (13 mm) E: 0.660 in. (17 mm) F: 1/2-14 NPT G: 0.875 Hex H: 11/16-20 UN-2A</p>	<ul style="list-style-type: none"> • Used with SPLC and 45TE • Rated: 5000 psi @ 300°F (345 bars @ 148°C) • Material: 316 Stainless Steel • Furnished with Compression Nut and Ferrule

Call MurCal To Place Your Order

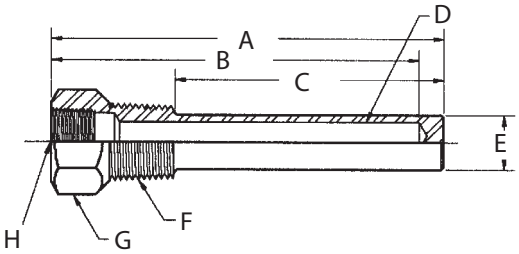
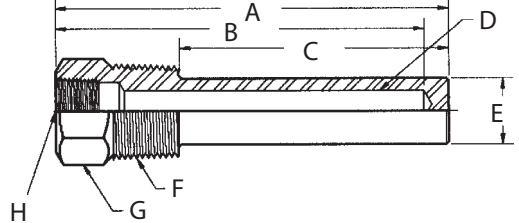

SDB Series Thermowells

PART NO.	DIMENSIONS	SPECIFICATIONS
10-05-0025	 <p>A: 4.800 in. (122 mm) B: 4.490 in. (114 mm) C: 3.300 in. (84 mm) D: 0.510 in. (13 mm) E: 0.660 in. (17 mm) F: 1/2-14 NPT G: 1.125 Hex H: 1/2-14 NPT</p>	<ul style="list-style-type: none"> • Used with SDB • Rated: 5000 psi @ 300°F (345 bars @ 148°C) • Material: 304 Stainless Steel
10-05-0311	 <p>A: 4.800 in. (122 mm) B: 4.490 in. (114 mm) C: 3.300 in. (84 mm) D: 0.510 in. (13 mm) E: 0.810 in. (21 mm) F: 3/4-14 NPT G: 1.125 Hex H: 1/2-14 NPT</p>	<ul style="list-style-type: none"> • Used with SDB • Rated: 7000 psi @ 300°F (483 bars @ 148°C) • Material: 304 Stainless Steel

20T, A20T, 25T, and A25T Series Thermowells

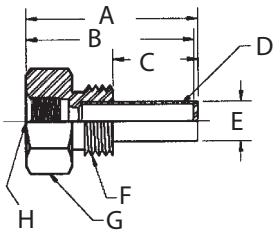
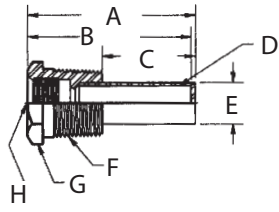
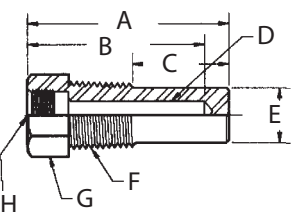
PART NO.	DIMENSIONS	SPECIFICATIONS
10-00-0425	 <p>A: 2.100 in. (53 mm) B: 2.053 in. (52 mm) C: 1.040 in. (26 mm) D: 0.430 in. (11 mm) E: 0.500 in. (13 mm) F: 7/8-9 UNC-2A G: 1.125 Hex H: 5/8-18 UNF-2B</p>	<ul style="list-style-type: none"> • Used with Bulb Type "A" * • Rated: 600 psi @ 250°F (41 bars @ 121°C) • Material: Carbon Steel Tube and Connection • Recommended for Engine Coolant and Lubrication Systems
10-01-0009	 <p>A: 2.053 in. (52 mm) B: 2.006 in. (51 mm) C: 1.140 in. (29 mm) D: 0.430 in. (11 mm) E: 0.500 in. (13 mm) F: 1/2-14 NPT G: 0.875 Hex H: 5/8-18 UNF-2B</p>	<ul style="list-style-type: none"> • Used with Bulb Type "A" * • Rated: 600 psi @ 250°F (41 bars @ 121°C) • Material: Carbon Steel Tube and Connection • Recommended for Engine Coolant and Lubrication Systems
10-05-0128	 <p>A: 2.475 in. (63 mm) B: 2.150 in. (55 mm) C: 1.193 in. (30 mm) D: 0.350 in. (9 mm) E: 0.660 in. (17 mm) F: 1/2-14 NPT G: 0.875 Hex H: 5/8-18 UNF-2B</p>	<ul style="list-style-type: none"> • Use with Bulb Style "A" * • Rated: 4000 psi @ 300°F (276 bars @ 149°C) • Material: 304 Stainless Steel

*Bulb Types are listed on Murphy Bulletin T-8428B.

20T, A20T, 25T, and A25T Series Thermowells

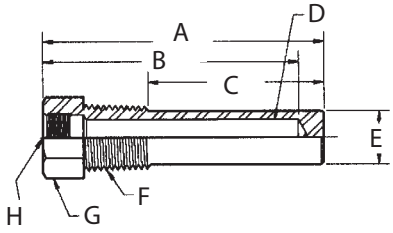
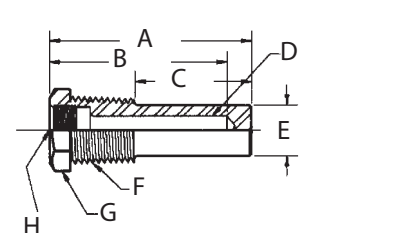
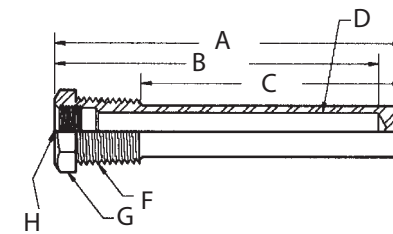
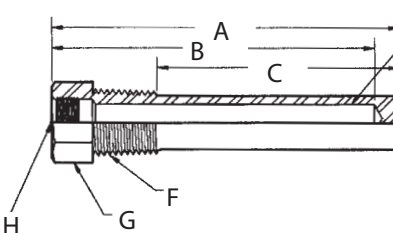
PART NO.	DIMENSIONS	SPECIFICATIONS
10-05-0169	 <p>A: 3.450 in. (88 mm) B: 3.138 in. (80 mm) C: 2.168 in. (55 mm) D: 0.453 in. (12 mm) E: 0.660 in. (17 mm) F: 1/2-14 NPT G: 0.875 Hex H: 5/8-18 UNF-2B</p>	<ul style="list-style-type: none"> • Use with Bulb Style “B” * • Rated: 4000 psi @ 300°F (276 bars @ 148°C) • Material: 304 Stainless Steel
10-05-0899	 <p>A: 2.475 in. (63 mm) B: 2.150 in. (55 mm) C: 1.445 in. (37 mm) D: 0.350 in. (9 mm) E: 0.640 in. (16 mm) F: 1/2-14 NPT G: 0.875 Hex H: 5/8-18 UNF-2B</p>	<ul style="list-style-type: none"> • Used with Bulb Type “A” * • Rated: 1000 psi @ 300°F (69 bars @ 148°C) • Material: Carbon Steel (Nickel Plated)
10-05-0900	 <p>A: 4.250 in. (108 mm) B: 3.950 in. (100 mm) C: 3.220 in. (82 mm) D: 0.456 in. (12 mm) E: 0.640 in. (16 mm) F: 1/2-14 NPT G: 0.875 Hex H: 5/8-18 UNF-2B</p>	<ul style="list-style-type: none"> • Used with Bulb Type “E” * • Rated: 1000 psi @ 300°F (69 bars @ 148°C) • Material: Carbon Steel (Nickel Plated)
10-05-0901	 <p>A: 4.250 in. (108 mm) B: 3.950 in. (100 mm) C: 2.968 in. (75 mm) D: 0.453 in. (12 mm) E: 0.660 in. (17 mm) F: 1/2-14 NPT G: 0.875 Hex H: 5/8-18 UNF-2B</p>	<ul style="list-style-type: none"> • Used with Bulb Type “E” * • Rated: 4000 psi @ 300°F (276 bars @ 148°C) • Material: 304 Stainless Steel

*Bulb Types are listed on Murphy Bulletin T-8428B.

Installation



WARNING: Before beginning installation, disconnect all electrical power to the machine. Make sure the machine cannot operate during installation. Follow all safety warnings of the machine manufacturer and read all installation instructions.

1. Screw the thermowell into the process (pipe line).
2. If using the SPL/45TE Thermowells, pass the sensing bulb through the compression nut and ferrule.
3. Apply temperature transmitter grease or silicon grease on the tip of the sensing bulb. This will facilitate heat transfer
4. Fully insert the sensing bulb into the thermowell housing and secure it by tightening the compression nut/fitting.

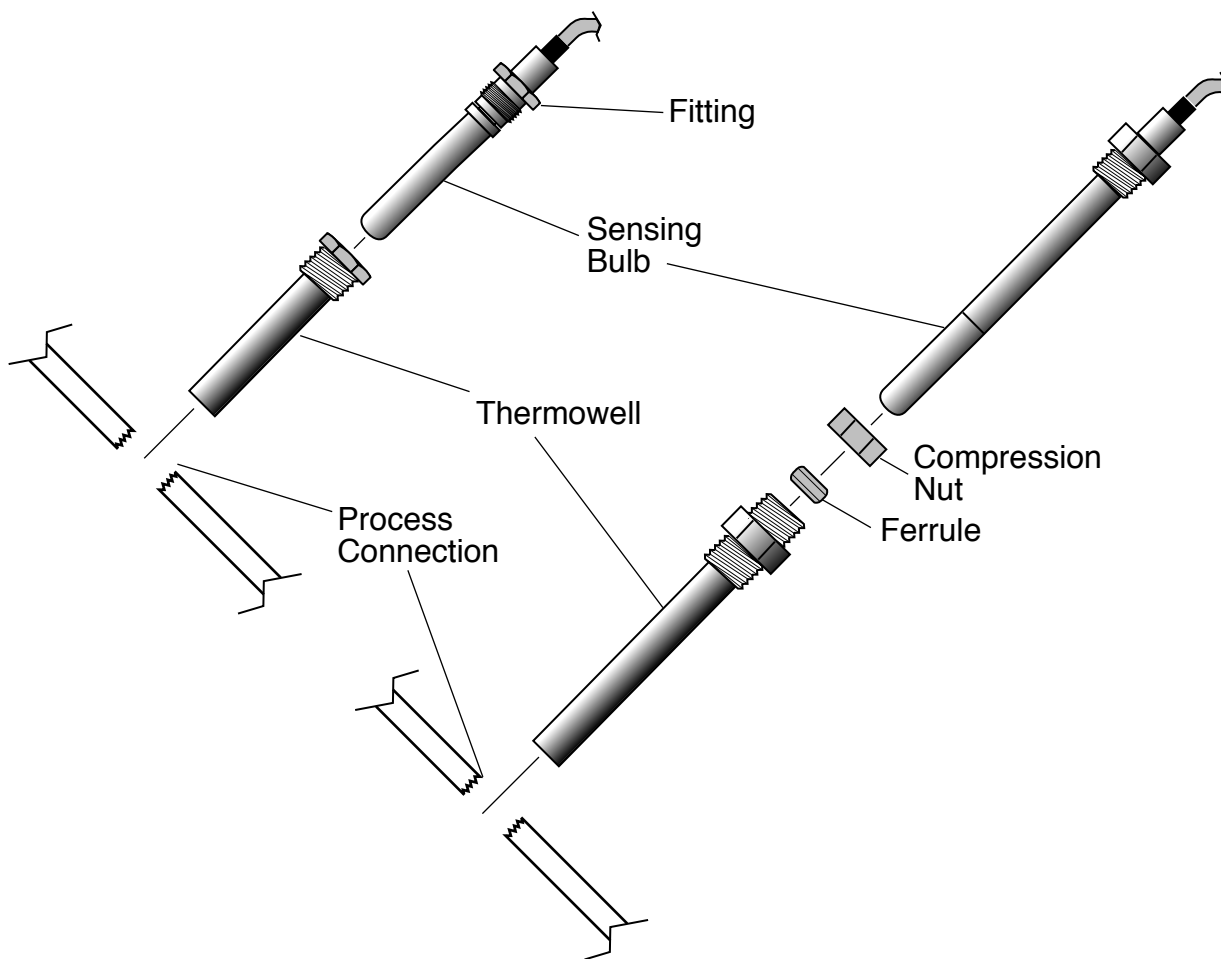

MURPHY®

Call MurCal To Place Your Order

MurCal®
(661) 272-4700 Fax: (661) 947-7570
www.murcal.com email: sales@murcal.com

